

GRID AUTOMATION PRODUCTS

Reliable Distribution Networks

Improved fault detection for overhead lines

The longer the overhead line, the higher is the need for enhanced observation and improved fault awareness. To insure the safety of people and of the network, Distribution grid owners and operators need to identify faults caused by broken lines and conductors. The RTU500 series offers the perfect solution for this challenge.

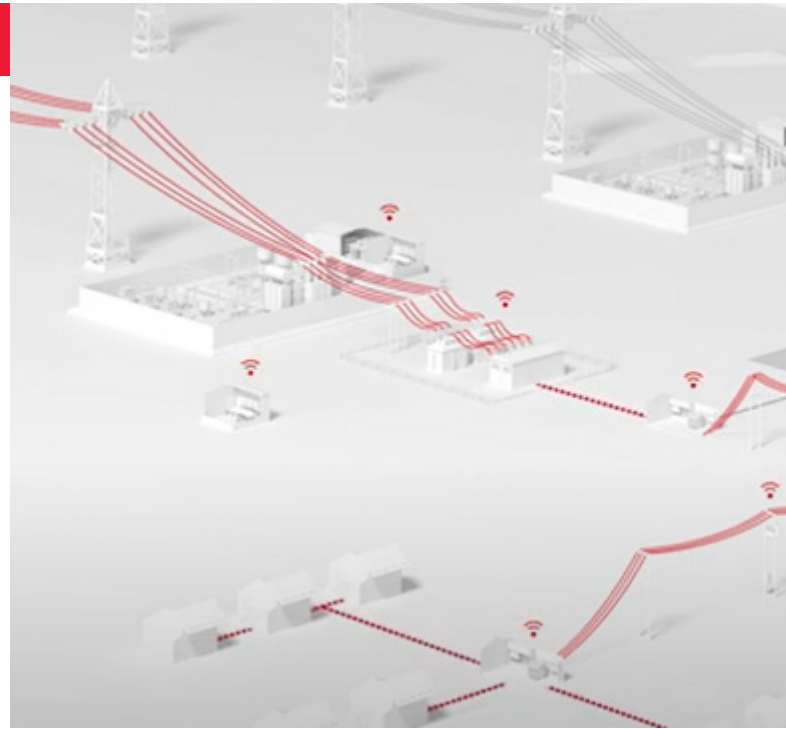

Challenges

Safety:

In secondary distribution grids the safety of the network is an important aspect. An energized broken conductor may result in a life-threatening situation, especially in urban areas. Safety hazards to persons, wildlife and the environment in rural areas cannot be disregarded. Utilities need to take special measures to identify and resolve those conditions to avoid claims and bad image.

Maintenance:

Today's challenge that more grid needs to be operated with less personal is a common trend all over the world. Open circuits like energized broken conductors run into high impedance and unbalanced faults. If not detected this will cause additional damage to the infrastructure. Classic overcurrent or earth-fault protection relays cannot detect those faults. An alternative solution is needed.

Solution

Hitachi Energy offers secondary grid automation solutions for overhead-lines, including intelligent measurement functionality. Both currents and voltages can be measured. High impedance and unbalanced faults can be detected, regardless if the faults are caused by broken or dropped overhead lines. An additional source of faults could be loose connecting cables or broken conductors or blown fuses of pole mounted transformers.

The solution supports fault detection functionality. This is based on directional and non-directional over-current and earth-faults algorithm. The fault location information allows the utility to take immediate actions to resolve dangerous situations.

Combining intelligent measurements with a fault recorder analysis helps to localize faults in a most efficient way. Detection and automation functionality reduces cost-intensive troubleshooting and increases safety of the service personnel. This leads to a stabilized grid, reduced outages times and can prevent damages (e.g. motor overheating)

Enabling products



500CVD90

- Measuring analog AC input signals from three independent phases with optional inputs for neutral current and voltage. (4xU, 4xI)
- Various ANSI detection function
- Power quality analysis according IEC61000-4-30
- Disturbance recorder (waveform capture) 2 binary outputs, 5 signalization LED's
- Metal housing



RTU530

- The logic-based algorithm in combination with the gateway functionality enables a wide range of usability
- Scalable input and output modules can be adapted based on customer application requirements
- Versatile combinations with intelligent multimeter 500CVD-series for indoor and outdoor applications
- Efficient footprint allows to fit the RTU530 into small control cabinets

Functions

- Broken/falling conductor detection
- Blown fuse detection
- Fault location
- Voltage monitoring
- Power quality monitoring
- Monitoring and remote control
- Local fault recorder reporting, readable with commercial Comtrade viewer

The small and flexible DIN-rail portfolio of RTU500 series is perfectly qualified for installations within limited space areas, like pole-top feeders. The product is designed for wide temperature range typical present in distribution applications.

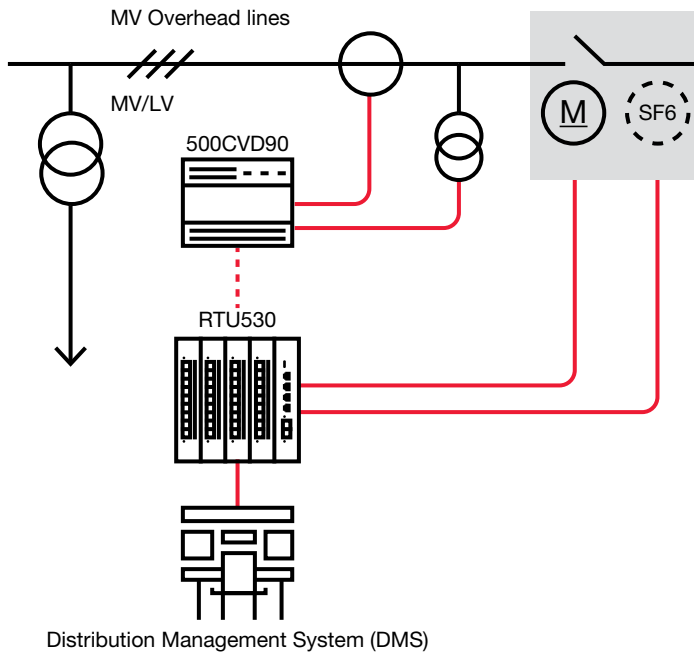

Application example

Benefits

- Eliminate safety hazard to people, animal life and fire ignition risk
- Increase safety for the utility personnel through reduced travel time and exact fault location
- Reduce SAIDI (System Average Interruption Duration Index)
- Reduce SAIFI (System Average Interruption Frequency Index)
- Single solution for fast restoration of the entire grid