

Binary output 520BOD01



Application

The binary output module 520BOD01 can be used for the control of 8 binary process signals using relay contacts. The allocation of an output signal to the processing functions can be done according to the rules of configuration.

The module 520BOD01 is able to process the following types of signals:

- Single or double commands (SCO or DCO) with 1 or 2 pole output without (1 out of n) check
- Single or double commands (SCO or DCO) with 1.5 or 2 pole output with (1 out of n) check
- Regulation step command (RCO), 1 or 2 pole
- Digital setpoints commands, 8 Bit without strobe (DSO8)
- Bitstring output, 1 or 8 Bit (BSO1 or BSO8)

The module allows switching voltages up to 150 V DC or max. 8 A continuous current.

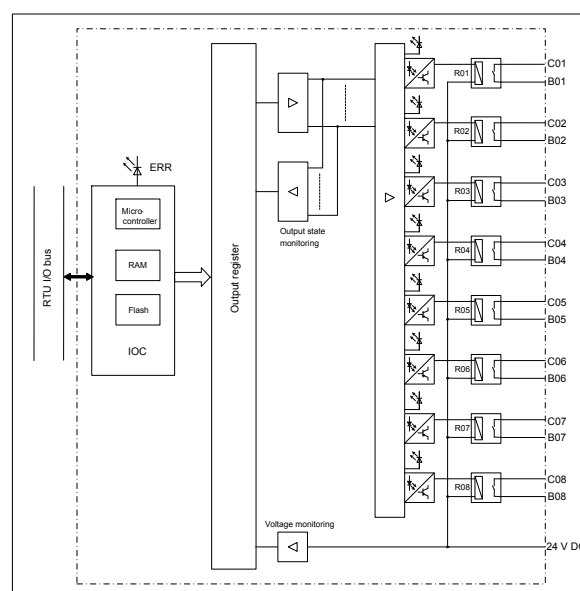

Figure 1: Block diagram 520BOD01

Characteristics

Binary outputs

Relay contacts are used for the binary outputs.

The 8 outputs are isolated from one another. In addition isolation against the internal electronic is done by optical coupler. All 8 relays contacts have a separated outputs and without common return.

The command output to the process equipment can be effected either directly or in conjunction with a command output supervision module. The command output supervision module covers the (1 out of n) check of the output circuits. More details can be found in the data sheet of the command output monitoring module.

Following modules with command output supervision function are supported:

- 560CIG10
- 560CID11
- 520CSD01

The 1.5 pole command output is only possible in combination with a command output supervision module. With the 1.5 pole command output, one output relay of the 520BOD01 switches the command to the interposing relay. The process voltage for the interposing relay is switched by the command output supervision module.

Two output relays are required for each command in case of 2 pole commands.

Before and during command output the module 520BOD01 carries out several command monitoring functions. These tests ensure correct output. With a command out monitoring module these tests can be further improved.

If the command monitoring detects fault the command will be canceled.

Power supply input

The required power for the module is supplied via the RTU520 I/O bus connector. In addition 24 V DC (U_E) is required (e. g. from 560PSU40/41). This voltage U_E has to be supplied from external and wired to the U_E connector.

I/O controller (IOC)

The micro-controller on the module processes all time critical tasks of the parameterized processing functions. Moreover it carries out the interactive communication with the RTU I/O bus. All configuration data and processing parameters are loaded by the communication unit via the RTU I/O bus.

In connection with an I/O adapter (e. g. 520ADD01) or the RTU520 communication unit the module is interfaced to the RTU520 I/O bus.

The binary output unit can execute the following processing functions on the individual signal types:

- Control of the command output duration

Command monitoring functions:

- (m out of 16) check of the output relays on the module
- monitoring of the output bit patterns by reading back the output state
- switching voltage monitoring (24 V DC coil voltage) before and during output only together with (1 out of n) control module
- command output duration monitoring

During initialization and operation the module carries out a number of tests. If a fault occurs it is reported to the communication unit. All fault conditions impairing the function of the module are displayed as common fault signal by a red LED. A failure of the module is detected by the communication unit.

Technical data

In addition to the RTU500 series general technical data, the following applies:

Output characteristics	
Outputs	8 Relay contacts, single pole, normal open
Max. switching voltage	150 V DC
Continuous current	8 A
Max breaking current (resistive load)	8 A ≤ 55 V DC 6 A @ 60 V DC 0.9 A @ 110 V DC
Max. breaking capacity (inductive load)	50 VA (L/R= 40 ms)
Pulsed output current, max. 30 seconds pulses with 50% Duty Cycle	10 A @ 30 VDC

Supply voltage input 24 V DC (U_E)	
Input voltage range	24 V DC (+/- 20%)
Current consumption	20 mA per active relay

Current consumption for power supplied via WRB bus	
5 V DC	70 mA
15 V DC	--
18 V DC	1 mA
24 V DC	--

Signaling by LEDs	
ERR (red)	Common fault information for the module
BO1... BO8	LED displays the active output relays

Mechanical layout	
Dimensions	47 mm x 98 mm x 117 mm (Width x Height x Depth)
Housing type	Plastic housing (V-0), IP20, RAL 7035 light gray
Mounting	DIN rail mounting EN 50022 TS35: 35 mm x 15 mm or 35 mm x 7.5 mm
Weight	0.3 kg

Connection type	
Process connector	2 x 8 pole 5.08 mm pluggable screw terminals (included in delivery) 0.2... 2.5 mm ² / AWG 24 - AWG 12
Power supply input	1 x 2 pole 5.08 mm pluggable screw terminals (included in delivery) 0.2... 2.5 mm ² / AWG 24 - AWG 12

Insulation tests

AC test voltage IEC 61000-4-16	2.5 kV, 50 Hz
IEC 60870-2-1 (class VW3)	Test duration: 1 min
Impulse voltage withstand test IEC 60255-5	5 kV (1.2 / 50 μs)
IEC 60870-2-1 (class VW 3)	
Insulation resistance IEC 60255-5	> 100 MΩ at 500 V DC

Immunity test

Electrostatic discharge IEC 61000-4-2	8 kV air / 6 kV contact (level 3)
	Performance criteria A
Radiated Radio-Frequency Electromagnetic Field IEC 61000-4-3	10 V/m (level 3)
	Performance criteria A
Electrical Fast Transient / Burst IEC 61000-4-4	4 kV (level X)
	Performance criteria A
Surge IEC 61000-4-5	4 kV (level 4)
	Performance criteria A
Conducted Disturbances, induced by Radio-Frequency Fields IEC 61000-4-6	10 V (level 3)
	Performance criteria A
Damped oscillatory wave IEC 61000-4-18	2.5 / 1 kV (level 3)
	Performance criteria A

Environmental conditions - climatic

Nominal operating temperature range EN 60068-2-14	-25 °C... 70 °C
Start up EN 60068-2-1	-40 °C
Max. operating temperature, max. 96h EN 60068-2-2	+85 °C
Relative humidity EN 60068-2-30	5... 95 % (non condensing)

Ordering information

520BOD01 R1002	1KGT033300R1002
----------------	-----------------

ABB AG
Power Grids
P.O. Box 10 03 51
68128 Mannheim, Germany
Tel. +49 621 381-3000

www.abb.com/remote-terminal-units

We reserve the right to make technical changes or modify the contents of this document without prior notice. With regard to purchase orders, the agreed particulars shall prevail. ABB AG does not accept any responsibility whatsoever for potential errors or possible lack of information in this document.

We reserve all rights in this document and in the subject matter and illustrations contained therein. Any reproduction, disclosure to third parties or utilization of its contents – in whole or in parts – is forbidden without prior written consent of ABB AG. Copyright© 2019 ABB AG
All rights reserved