

DIN Rail RTU 540CID01

RTU540 product line



RTU540 base modul with 2 Ethernet ports

- Metal housing
- 4x serial port (RS-232 or RS-485)
- 2x Ethernet interface (10/100BaseT)
- USB configuration interface
- Power supply 24... 125 V DC (galvanic isolated)
- Integrated I/O (16 binary inputs, 8 binary outputs, 8 analog inputs)
- (1 out of n) check
- With connection interface to RTU500 I/O-extension modules
- Battery buffered real time clock

Application

The 540CID01 is a module of the RTU540 product line consisting of a communication unit (CMU), a multi-I/O module (IOM) and a galvanic isolated wide range power supply (PSM) in a metal DIN rail housing.

The essential tasks are:

- Managing and controlling of the RTU520 I/O modules via the serial I/O bus
- Reading Process events from the input modules.
- Send commands to the output modules.
- Communicating with control systems and local HMI systems via the serial interface and the Ethernet interfaces.
- Communication with Sub-RTU's, IED's or multimeter devices via the serial interface and the Ethernet interfaces.
- Managing the time base for the RTU540 product line station and synchronizing the I/O modules.
- Handling the dialog between RTU540 product line and Web-Browser via the LAN and USB interfaces.
- Capturing of 8 analog input signals (mA or V signals), fast scan cycle of 100 ms for 2 inputs
- Capturing of 16 digital input signals, 1 high speed counter input (max. 16 kHz)
- 8 output contacts (normal open), 1 or 2 pole output

The unit has a battery buffered real time clock (RTC).

The unit is available in two versions:

- R0001: process voltage 24 ... 60 V DC
- R0002: process voltage 110 ... 125 V DC

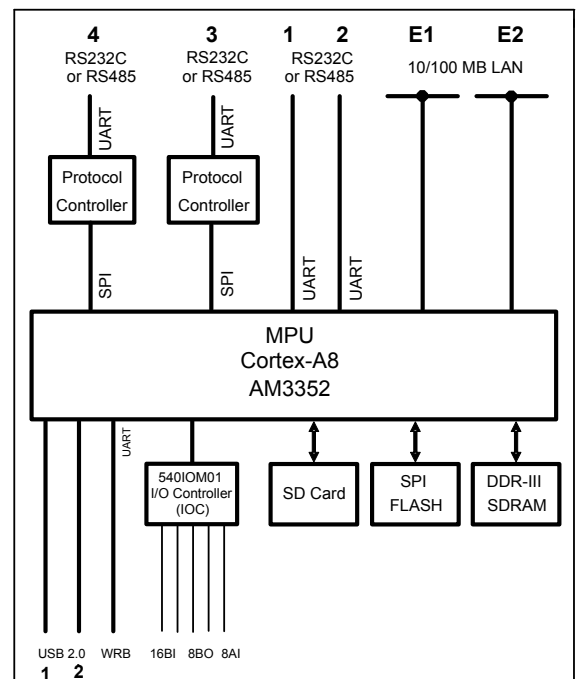

Figure 1: Function block diagram 540CID01

Characteristics

Communication unit

On the applied ARM cortex A8 controller AM3352 a real-time operating system is implemented. The 540CID01 is responsible for the interface management, the event handling, the time base and the internal data base. The controller acts as master for the serial I/O bus (WRB).

System relevant configuration files are stored in the non-volatile flash memory card (removable SD-card™) in order to guarantee a valid system configuration after Power on Reset (PoR).

A battery buffered RTC is used to keep an exact time during power off state.

The communication unit provides the following interfaces:

- Communication Port 1 ... 4 (CP1 ... CP4): serial interfaces according RS232C or RS485 with RJ45 connectors.
- Ethernet interface 1 and 2 (E1 & E2): 10/100BaseT with RJ45 connector.
- USB 2.0 device interface for diagnosis and maintenance purposes.
- USB 2.0 host interface for future extensions.
- WRB I/O bus interface for local communication with the I/O-modules

I/O controller (IOC)

The micro-controller on the module processes all time critical tasks of the parameterized processing functions. Moreover it carries out the interactive communication with the RTU I/O bus. All configuration data and processing parameters are loaded by the communication unit via the RTU I/O bus.

The binary input unit can execute the following processing functions for the different types of signals:

- Digital filtering to suppress contact bounce
- Suppression of oscillating signals caused by the process
- Validity check and suppression of intermediate input states for double indications
- Consistency check for all channels allocated to digital measured values or step position information
- Summation of increment pulses to form integrated totals in registers of 31 bit resolution
- Copying of integrated totals values into freezing registers for data conservation

The binary output unit can execute the following processing functions on the individual signal types:

- Control of the command output duration

Command monitoring functions:

- (m out of 8) check of the output relays on the module
- switching voltage monitoring (24 V DC coil voltage) before and during output
- command output duration monitoring

The analog input unit can execute the following processing functions on the measured values:

- Scan cycle and line frequency interference suppression
- Zero value supervision and switching detection
- Smoothing

- Threshold value monitoring on absolute value or with accumulation
- Periodic transmission and background cycles

The module provides a data buffer for temporally storing of up to 160 event messages including time stamps. The events are stored in chronological order designated for transmission to the communication unit (CMU).

During initialization and operation the module carries out a number of tests. If a fault occurs it is reported to the communication unit. All fault conditions impairing the function of the module are displayed as common fault signal by a red LED. A failure of the module is detected by the communication unit.

Binary input unit

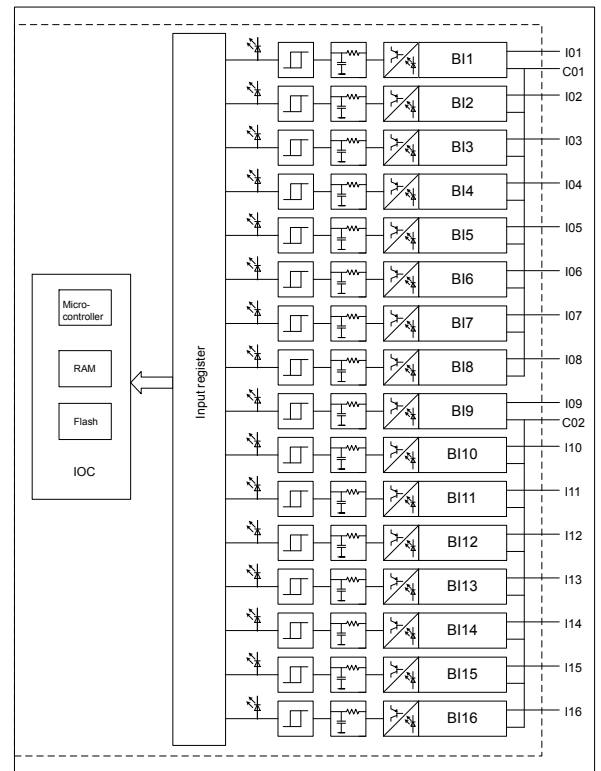

Figure 2: Block diagram 540IOM01 binary input unit

The module 540CID01 provides 16 galvanic isolated inputs for up to 16 binary process signals. Scanning and processing of the inputs are executed with the high time resolution of 1 ms. The allocation of an input signal to the processing functions can be done according to the rules of configuration.

The module 540CID01 is able to process the following types of signals or a combination of them:

- 16 single point information with time stamp (SPI)
- 8 double point information with time stamp (DPI)
- 2 digital measured values each with 8 bit (DMI8)
- 1 digital measured value with 16 bit (DMI16)
- 16 integrated totals (max. 120 Hz) (ITI), including 1 high speed counter (max. 16 kHz)
- 2 step position information each with 8 bit (STI)
- 2 bitstring input each with 8 bit (BSI8)
- 1 bitstring input with 16 bit (BSI16)
- or combinations of this signal types

The module is available in two versions (rubrics):

- 540CID01 R0001: process voltage 24 to 60 V DC. LED signaling for each input, common return per 8 inputs.
- 540CID01 R0002: process voltage 110 to 125 V DC. LED signaling for each input, common return per 8 inputs.

The inputs are galvanic isolated by means of optical couplers. 8 inputs are building a group with a common return. The input circuit is designed to keep the input current constant by using current regulative diodes.

The binary input channels are protected against reverse voltage installation. If the input signal is installed with wrong polarity the input current will be zero.

The module has 16 LEDs to indicate the signal state at the inputs. The LEDs follow direct the input signal.

The maximum permissible frequency for counter pulses is 120 Hz. The input BI1 can be used up to 16 kHz (at 50% duty cycle).

Analog input unit

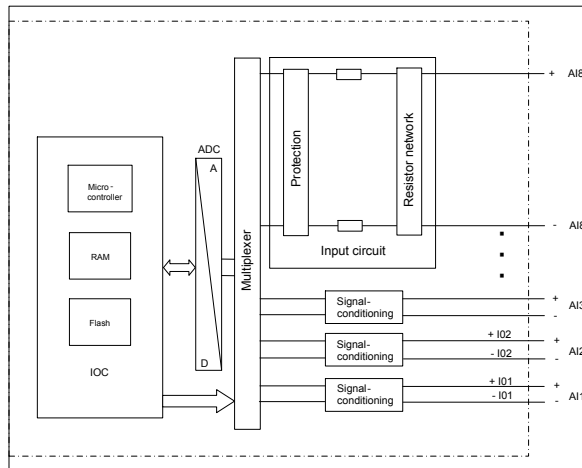

Figure 3: Block diagram 540IOM01 analog input unit

The 540CID01 module records up to 8 analog measured values.

The module 540CID01 is able to process the following types of signals:

- Analog measured values (AMI)
- Measured floating point information (MFI)

Following measurement ranges can be configured:

- ± 2 mA
- ± 5 mA
- ± 10 mA
- ± 20 mA
- ± 40 mA
- ± 2 V DC
- ± 20 V DC

Other effective ranges and live zero signals become generated out of these ranges through conversion of the communication unit (CMU).

Basic signal checks and cyclic processing functions are already be done locally in order to unburden the communication unit. The module transmits relevant changes as event via the RTU I/O bus.

The 8 differential inputs are not galvanic isolated against the power supply.

Single-ended or differential input values are resolved by up to 4096 steps (12 bit plus sign) for 100 % measurement amplitude.

The differential inputs are protected against static and dynamic over-voltages by a protection circuit. A low-pass filter suppresses unwanted frequency components.

The internal high resolution of the AD converter allows to scan all measuring ranges with the same resolution.

For elimination of tolerances a calibration is done during production.

The synchronization of the scan cycle with the line frequency is used to increase the line frequency interference suppression of the DC input signal.

Frequency	Conversion time per channel	Scan cycle time (same for all channels)
60 Hz	50 ms	400 ms (fast scan AI1 & AI2: 100 ms)
50 Hz	60 ms	480 ms (fast scan AI1 & AI2: 100 ms)
16.7 Hz	180 ms	1440 ms (fast scan AI1 & AI2: 200 ms)

Binary output unit

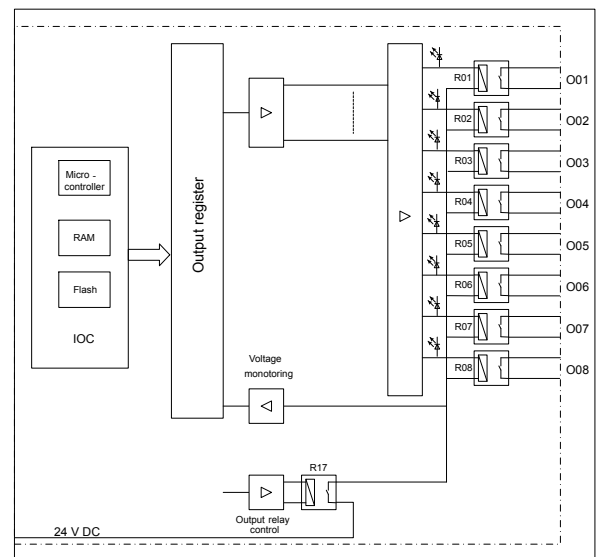

Figure 4: Block diagram 540IOM01 binary output unit

The module 540CID01 can be used for the control of 8 binary process signals using relay contacts. The allocation of an output signal to the processing functions can be done according to the rules of configuration.

The module 540CID01 is able to process the following types of signals:

- Single or double commands (SCO or DCO) with 1 or 2 pole output without (1 out of n) check
- Single or double commands (SCO or DCO) with 1.5 or 2 pole output with (1 out of n) check

- Regulation step command (RCO), 1 or 2 pole
- Digital setpoints commands, 8 Bit without strobe (DSO8)
- Digital setpoint commands, 8 Bit with strobe (DSO8)
- Bitstring output, 1, 2 or 8 Bit (BSO1, BSO2 or BSO8)

The module allows switching voltages up to 250 V DC or max. 8 A continuous current.

Relay contacts are used for the binary outputs.

The 8 outputs are isolated from one another. All 8 relays contacts have individual contacts without a common return.

The supply voltage for the coils of the relays (24 V DC) is monitored internally before and during the command output.

Two output relays are required for each command in case of 2 pole commands.

Before and during command output the module 540CID01 carries out several command monitoring functions. These tests ensure correct output.

If the command monitoring detects fault the command will be canceled.

(1 out of n) check circuit

The check circuit for measuring the resistance of the relay coil is galvanic isolated against the other electronic voltage and against the switching voltage (UP) of the interposing relays.

The essential features are:

- Galvanic isolation of the check circuit done by means of a galvanic isolated DC/DC-converter and optocouplers
- Suppression of line frequency during resistance measuring

The (1 out of n) check of the 540CID01 module measures the resistance value in the output circuit and compares this value with the configured upper and lower limit values. If the resistance value is within the limits the selected interposing relay can be activated. The object command will be acknowledged positively. If the measured resistance value is outside the tolerance limits the 540CID01 blocks the output and indicates the error to the communication unit (CMU).

After one command relays (B01..B08 or on another 520BOD01) has switched on, the 540CID01 gets the order to check and process the object command. The 540CID01 switches the output circuit to the check circuit via the external "check" relay (R10). The resistance is determined by the arising measuring circuit voltage by output of a constant current. If the measured resistance value is within the tolerance range, the "check" relay is switched. After that the external "GO" relay (R09) switches the selected interposing relay and releases the object command.

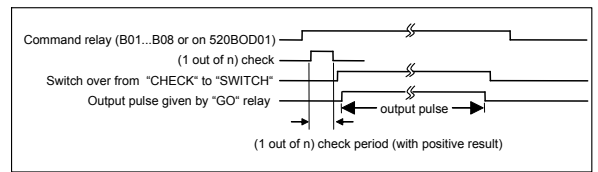

Figure 5: Time diagram of the (1 out of n) check circuit

To ensure correct output the board carries out several monitoring functions before and during command output:

- Monitoring of output duration and reset in case of fault
- Monitoring of switching voltage before and during the command output

Main Supply Supervision (MSS)

The monitoring function (MSS) is used to test and to supervise Battery Voltage Supply units. MSS gives the status that the Battery is in good condition and all connections and fuses are OK. In case of a Failure or in a Warning situation The 540CID01 detects this at the MSS input and generates a message.

MSS input unit can detect 4 different states:

- Normal operation = High signal
- AC Failure = 0,5 Hz signal
- Battery Failure = 2,0 Hz signal
- Wiring or Fuse Failure = Low signal

If this MSS functionality is configured then the 540CID01 will report a Warning or Alarm situation to the central station. In addition the 540CID01 can switch the ALARM-output (X6) in case of any error.

Alarm Output (ALR)

If an error condition occurs in the RTU the ALR- output will be switched. RTU error conditions have to be taken from the function description of the RTU500 series releases.

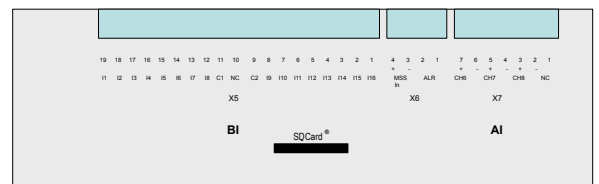

Figure 6: Top side of 540CID01 housing

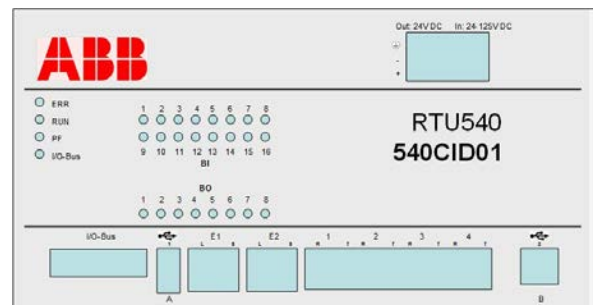

Figure 7: Front side of 540CID01 housing

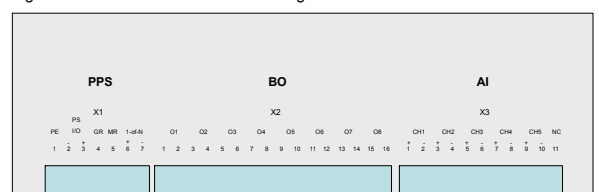

Figure 8: Bottom side of 540CID01

Technical data

In addition to the RTU500 series general technical data, the following applies:

Main Processing Unit MPU	
CPU	ARM cortex A8, AM3352 @ 800 MHz
RAM	256 MByte
Boot Flash	8 MByte

SD card	
Connector	SD card slot (push push)
Type	SD 2.0, class 2
Capacity	4 GByte

Real time clock RTC (Backup)	
Battery	Lithium 3 V DC, CR2032
Time resolution	1 sec, 1ms with timesync
Battery lifetime	> 10 years
Free running	± 50 ppm

Serial interfaces 1, 2, 3, 4	
Connector	RJ45
Type	RS232C or RS485
RS232C:	
Bit rate	200 bit/s - 38.4 kbit/s
Signal lines	GND E2/102
	TxD D1/103
	RxD D2/104
	RTS S2/105
	CTS M2/106
	DTR S1.2/108
	DCD M5/109
Level	typical: ± 6V
RS485:	
Bit rate	200 bit/s - 38.4 kbit/s
Level	typical: ± 6V

Ethernet interface E1 and E2	
Connector	RJ45
Type	IEEE 802.3, 10/100BaseT

USB interface 1	
Connector	USB Type A (for future extensions)
Type	USB 2.0 host, low and full speed (max. 12 MBit/s)

USB interface 2	
Connector	USB Type B (configuration interface)
Type	USB 2.0 device, low and full speed (max. 12 MBit/s)

Signaling by LEDs

ERR (red)	ON: RTU in error state Flashing: RTU in warning state For more details see RTU500 series Function Description
RUN (green)	Communication module in operation
PF (red)	Failure of one of the internal voltages (24 V DC out not included)
I/O bus (green)	Transmission on to the I/O bus
T	Transmit data on serial communication ports CP
R	Receive data on serial communication ports CP
S	Ethernet communication speed: ON: 100 Mbit/s OFF: 10 Mbit/s
L	Link up on Ethernet interface E

Binary input channels 540CID01 R0001

Inputs	16 channels, common return for 2 groups of 8 channels, isolated by opto-couplers
Nominal input voltage	24... 60 V DC (+/- 20%)
Max. input voltage	72 V DC
Input current	typ. 2 mA constant
Logical '1' definitely detected	≥ 18 V DC
Logical '0' definitely detected	≤ 9 V DC
Reverse voltage protection	yes
Max. input frequency for integrated totals	120 Hz (high speed channel BI1: 16 kHz)

Binary input channels 540CID01 R0002

Inputs	16 channels, common return for 2 groups of 8 channels, isolated by opto-couplers
Nominal input voltage	110... 125 V DC (+/- 20%)
Max. input voltage	152 V DC
Input current	typ. 1,2 mA constant
Logical '1' definitely detected	≥ 80 V DC
Logical '0' definitely detected	≤ 45 V DC
Reverse voltage protection	yes

Binary input channels 540CID01 R0002	
Max. input frequency for integrated totals	120 Hz (high speed channel BI1: 16 kHz)

Binary output characteristics	
Outputs	8 Relay contacts, single pole, normal open
Max. switching voltage	250 V DC
Continuous current	8 A
Max breaking current (resistive load)	8 A ≤ 55 V DC 6 A @ 60 V DC 0.9 A @ 110 V DC 0.3 A @ 220 V DC
Max. breaking capacity (inductive load)	50 VA (L/R= 40 ms)
Pulsed output current, max. 30 seconds pulses with 50% Duty Cycle	10 A @ 30 VDC

Analog input channels 540CID01	
Inputs	8 differential inputs
Configurable measuring range	<ul style="list-style-type: none"> • ± 2 mA • ± 5 mA • ± 10 mA • ± 20 mA • ± 40 mA • ± 2 V DC • ± 20 V DC
Input impedance	150 Ω @ ±2 to ±10 mA 50 Ω @ ±20 and ±40 mA 110 kΩ @ ±2 and ±20 V DC
Max. load	80 mA continuous @ ±20 and ±40 mA 40 mA continuous @ ±2 to ±10 mA 38 V / 0.5 mA @ ±2 and ±20 V DC
Resolution	12 bit + sign 11 bit + sign @ ±2 V DC
AD converter resolution	24 bit
Accuracy at 25 °C	≤ 0.1 % ≤ 0.2 % @ ±2 V DC
Linearity error at 25 °C	≤ 0.1 %
Temperature drift	≤ 100 ppm/K (0... 70 °C)
Max. common mode input voltage	±150 V DC (electrical limit) ±8 V DC (functional limit)
Max. differential input voltage	± 4 V DC (current input) ± 38 V DC (voltage input)
Common mode rejection	> 70 dB @ 25 °C > 60 dB @ 0... 25 °C
Configurable line frequency f_N	<ul style="list-style-type: none"> • 16.7 Hz • 50 Hz • 60 Hz

Analog input channels 540CID01	
Line frequency interference suppression	> 100 dB @ $f_N \pm 2\%$ > 45 dB @ $f_N \pm 10\%$

Signaling by LEDs	
BI 16x (yellow)	LED displays the active inputs
BO 8x (yellow)	LED displays the active output relays

ALR (Alarm Output)	
Alarm (ALR):	Normal closed (NC), isolated
Relay contact	
Max. contact current:	8 A
Max. contact voltage:	250VDC
Max. switching power:	120W resistive 50W at L/R=40ms

MSS (Main Supply Supervision)	
MSS:	24V, 48V, 60VDC
Digital Input:	≥ 18V = Logic 1 ≤ 9V = Logic 0
Input current:	2mA constant
Over-voltage protection:	72VDC
Reverse voltage protection:	yes

PPS (Process Power Supervision)	
Process voltage input:	24 / 48 / 60VDC (R0001)
PS (I/O):	110 / 125VDC (R0002)
GO Relay (GR):	Coil voltage: 24VDC, max. 0,1A
Meas Relay (MR):	Coil voltage: 24VDC, max. 0,1A
Input current:	2mA constant
Over-voltage protection:	Max. 72VDC (R0001) Max. 152VDC (R0002)
Reverse voltage protection:	yes

Power supply input	
Input voltage	24 ... 125 V DC
Input tolerance range	-20%... +20%
Max. input current	2 A
Starting current	<20 A; 50µs - 1.5ms (Class S1 according to IEC 60870-4)
Efficiency	88% @24 V DC
Power consumption	8.7 W (0.1 A @ 24 V out)

Power supply input	
External circuit-breaker	The plus lead has to be protected by an upstream circuit-breaker with 10 A tripping current.
Reverse voltage protection	yes
Galvanic isolated between primary circuit and secondary circuit	yes
Power supply output	
Total output power	30 W
24 V DC power supply output	
Voltage	24 V DC (galvanic isolated)
Tolerance	±20 %
Max. current	500 mA
Residual ripple	≤ 200 mV _{PP}
Current supply for power supplied via WRB bus	
5 V DC (±5 %)	1.8 A
±15 V DC (±10 %)	200 mA
18 V DC (±20 %)	50 mA
Mechanical layout	
Dimensions	204 mm x 105 mm x 90 mm (Width x Height x Depth)
Housing type	Metal case
Mounting	DIN rail mounting (EN 50022 TS35: 35 mm x 15 mm or 35 mm x 7.5 mm)
Enclosure protection class	IP20
Weight	ca. 1,3 kg
Connection type	
Power Supply:	2 x 3 pole pluggable screw terminals
Binary Input:	19 pole pluggable screw terminals
Binary Output:	16 pole pluggable screw terminals
(1 out of n) check:	7 pole pluggable screw terminals
Analog Input:	11 and 7 pole pluggable screw terminals
MSS / Alarm:	4 pole pluggable screw terminals
IO- Interface:	1 x 20- pole
Wirde- OR- Interface:	Pluggable connectors
Ethernet Interface E1 and E2:	RJ45 jack, 8 pole
Serial Interfaces 1, 2, 3, 4:	RJ45 jack, 8 pole

Insulation tests	
AC test voltage IEC 61000-4-16 IEC 60870-2-1 (class VW3)	2.5 kV, 50 Hz Test duration: 1 min
Impulse voltage withstand test IEC 60255-5 IEC 60870-2-1 (class VW 3)	5 kV (1.2 / 50 µs)
Insulation resistance IEC 60255-5	> 100 MΩ at 500 V DC
Immunity test	
Electrostatic discharge IEC 61000-4-2	8 kV air / 6 kV contact (level 3) Performance criteria A
Electrical fast transient / Burst IEC 61000-4-4	4 kV (level 4) Performance criteria A
Surge IEC 61000-4-5	4 kV (level 4) Performance criteria A
Conducted disturbances, induced by radio-frequency fields IEC 61000-4-6	10 V (level 3) Performance criteria A
Damped oscillatory wave IEC 61000-4-18	2.5 / 1 kV (level 3) Performance criteria A
Environmental conditions - climatic	
Nominal operating temperature range EN 60068-2-14	-25 °C ... 70 °C
Start up EN 60068-2-1	-40 °C
Relative humidity EN 60068-2-30	5... 95 % (non condensing)

Ordering information

540CID01 R0001 1KGT037300R0001

process voltage 24 ... 60 V
DC

540CID01 R0002 1KGT037300R0002

process voltage 110 ... 125
V DC

ABB Power Grids Germany AG

P.O. Box 10 03 51
68128 Mannheim, Germany

hitachiabb-powergrids.com/rtu

We reserve the right to make technical changes or modify the contents of this document without prior notice. With regard to purchase orders, the agreed particulars shall prevail. ABB Power Grids Germany AG does not accept any responsibility whatsoever for potential errors or possible lack of information in this document.

We reserve all rights in this document and in the subject matter and illustrations contained therein. Any reproduction, disclosure to third parties or utilization of its contents – in whole or in parts – is forbidden without prior written consent of ABB Power Grids Germany AG.
© 2021 Hitachi Power Grids
All rights reserved

ABB is a registered trademark of ABB Asea Brown Boveri Ltd. Manufactured by/ for a Hitachi Power Grids company.