

Binary output 560BOR01

RTU560 product line



Binary output, 16 channels

- 16 output contacts configured as
 - 1-pole command
 - 2-pole command
 - 1.5-pole command in configuration with 23BA23
- Operating voltage 24...125 V DC, 60 W
- I_{max}: 2 A ≤ 30 V DC (resistive load)

Application

The module 560BOR01 of the RTU560 product line can be used for the control of 16 binary process signals using relay contacts. The allocation of an output signal to the processing functions can be done according to the rules of configuration.

The module 560BOR01 is able to process the following types of signals:

- Single or double commands (SCO or DCO) with 1 or 2 pole output
- Single or double commands (SCO or DCO) with 1.5 or 2 pole output with (1 out of n) check
- Regulation step command (RCO), 1 or 2 pole
- Digital setpoints commands, 8 or 16 Bit without strobe (DSO8 or DSO16)
- Digital setpoint commands, 8 or 16 Bit with strobe (DSO8 or DSO16)
- Bitstring output, 1, 2, 8 or 16 Bit (BSO1, BSO2, BSO8 or BSO16)

The module allows switching voltages up to 150 V DC or max. 2 A continuous current.

The module is available in two versions (rubrics):

- 560BOR01 R0002
- 560BOR01 R0102 pin and function compatible with R0002, only an alternative IO controller is used.

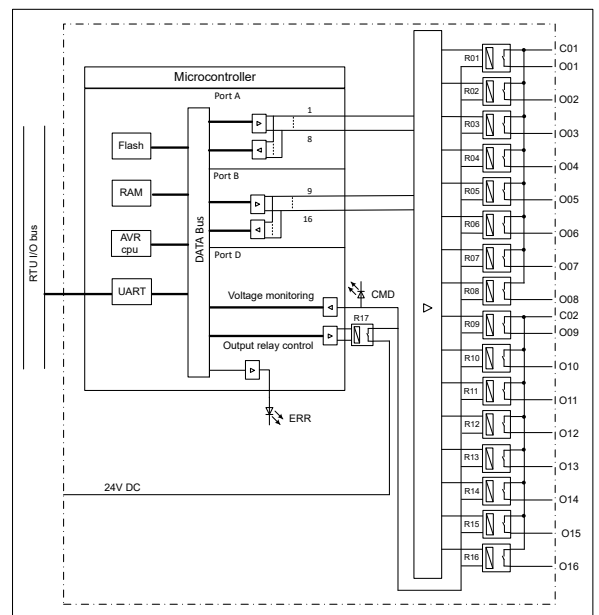

Figure 1: Block diagram 560BOR01

Characteristics

Binary outputs

Relay contacts are used for the binary outputs.

The 16 outputs are combined into two groups. Each 8 outputs have a common return. The groups are isolated from one another as well as from the internal electronic.

The supply voltage for the coils of the relays (24 V DC) is switched by an internal switching transistor and is monitored internally before and during the command output.

The command output to the process equipment can be effected either directly or in conjunction with a command output supervision module. The command output supervision module covers the (1 out of n) check of the output circuits. More details can be found in the data sheet of the command output monitoring module.

Following modules with command output supervision function are supported:

- 23BA23 (max. 60 V DC)

The 1.5 pole command output is only possible in combination with a command output supervision module. With the 1.5 pole command output, one output relay of the 560BOR01 switches the command to the interposing relay. The process voltage for the interposing relay is switched by the command output supervision module.

Two output relays are required for each command in case of 2 pole commands.

Another possibility for direct switching of process relays on electrical apparatus (disconnectors, circuit-breakers) with high switching capacity is given by using an additional booster relay connected to the command output monitoring module 23BA23 (see 23BA23 Data sheet).

Before and during command output the module 560BOR01 carries out several command monitoring functions. These tests ensure correct output. With a command output monitoring module these tests can be further improved.

If the command monitoring detects fault the command will be canceled. The switching through of the output relays by the release relay R17 occurs only after a successful test. A defective driver or a fault in the release relay R17 leads to complete inhibition of the command output module.

Power supply input

The required power for the module is supplied via the RTU560 backplane.

I/O controller (IOC)

The micro-controller on the module processes all time critical I/O tasks of the parameterized processing functions. Moreover it carries out the interactive communication with the RTU560 I/O bus. All configuration data and processing parameters are loaded by the communication unit via the RTU560 I/O bus.

The module is equipped with a serial interface to the RTU560 I/O bus on the backplane.

The binary output unit can execute the following processing functions on the individual signal types:

- Control of the command output duration

Command monitoring functions:

- (m out of 16) check of the output relays on the module
- monitoring of the output bit patterns by reading back the output state
- switching voltage monitoring (24 V DC coil voltage) before and during output
- command output duration monitoring

During initialization and operation the module carries out a number of tests. If a fault occurs it is reported to the communication unit. All fault conditions impairing the function of the module are displayed as common fault signal by a red LED. A failure of the connected module(s) is detected and signaled by the communication unit.

Technical data

In addition to the RTU500 series general technical data, the following applies:

| Binary output channels 560BOR01 | |
|--|---|
| Outputs | 16 Relay contacts, single pole, normal open, 2 groups of 8 outputs with common return |
| Coil voltage | 24 V |
| Max. switching voltage | 150 V DC |
| Continuous current | 2 A total current for one group with the same common return |
| Max breaking current (resistive load) | 2 A @ 30 V DC 1 A @ 60 V DC 0.3 A @ 110 V DC 0.15 A @ 150 V DC |
| Max. breaking capacity (inductive load) | 50 VA (L/R= 40 ms) |
| AC dielectric voltage test, IEC 60255-27, IEC 61000-4-16, IEC 60870-2-1 (class VW3) | 2.5 kV, 50 Hz, 1 min |
| Impulse voltage withstand test of insulation, IEC 60255-27, IEC 60870-2-1 (class VW3) | 5 kV (1.2 / 50 μ s) |
| Electrical fast transient / Burst, IEC 61000-4-4 | 4 kV (level 4), criterion A |
| Surge 1.2/50 μ s, IEC 61000-4-5 | 4 kV (level 4), criterion A |
| Conducted disturbances, induced by radio-frequency fields, IEC 61000-4-6 | 10 V (level 3), criterion A |
| Conducted, common mode disturbances in the frequency range 0 Hz to 150 kHz, IEC 61000-4-16 | 30 V continuous disturbance/ 300 V short duration disturbance (level 4), criterion A |
| Damped oscillatory wave, IEC 61000-4-18 | 2.5 kV line to earth, 1 kV line to line (level 3), criterion A |

Current consumption for power supplied via RTU560 backplane

| | |
|---------|------------------------|
| 5 V DC | 120 mA |
| 24 V DC | 10 mA per active relay |

Signaling by LEDs

| | |
|-----------|---|
| ERR (red) | Common fault information for the module |
| CMD | Command output, displayed during active output time of any output relay |

Mechanical layout

| | |
|--------------|---|
| Dimensions | 160 mm x 100 mm, 3HE euro card format 4R (20 mm) front panel |
| Housing type | Printed circuit board |

Mechanical layout

| | |
|----------|------------------------------|
| Mounting | for mounting in RTU560 racks |
| Weight | 0.3 kg |

Connection type

| | |
|----------------------------|--------------------------|
| RTU560 backplane connector | 48 pole type F DIN 41612 |
|----------------------------|--------------------------|

Insulation tests

| | |
|---|---|
| Insulation classification according to | IEC 60664-1 <ul style="list-style-type: none">• Pollution degree 2• Overvoltage category II• Altitude: \leq 3,000 m Pollution degree 2 |
| | Overvoltage category II |
| | Altitude: \leq 3,000 m |
| AC dielectric voltage test, IEC 60255-27, IEC 61000-4-16, IEC 60870-2-1 (class VW3) | 2.5 kV, 50 Hz Test duration: 1 min |
| Impulse voltage withstand test of insulation, IEC 60255-27, IEC 60870-2-1 (class VW3) | 5 kV (1.2 / 50 μ s) |
| Insulation resistance, IEC 60255-27 | $>$ 100 M Ω at 500 V DC |
| Insulation resistance to earth at 500 V DC, IEC 60255-27 | 500 V DC isolated for 1 min |
| Inverted polarity and voltage ramp delay, IEC 60255-27 | 1 V/ min |

Immunity test

| | |
|---|-----------------------------------|
| Electrostatic discharge IEC 61000-4-2 | 8 kV air / 6 kV contact (level 3) |
| | Performance criteria A |
| Electrical fast transient / Burst IEC 61000-4-4 | 2 kV (level 3) |
| | Performance criteria A |
| Surge IEC 61000-4-5 | 2 kV (level 3) |
| | Performance criteria A |

Environmental conditions - climatic

| | |
|---|--------------------------------------|
| Operating temperature EN 60068-2-14 | -25 $^{\circ}$ C ... 70 $^{\circ}$ C |
| Start up EN 60068-2-1 | -40 $^{\circ}$ C |
| Max. operating temperature, max. 96h EN 60068-2-2 | +85 $^{\circ}$ C |
| Relative humidity EN 60068-2-30 | 5 ... 95 % (non condensing) |

Ordering information

| | |
|---------------|----------------|
| 560BOR01 R002 | 1KGT036800R002 |
|---------------|----------------|

| | |
|----------------|-----------------|
| 560BOR01 R0102 | 1KGT036800R0102 |
|----------------|-----------------|

Hitachi Energy Germany AG
P.O. Box 10 03 51
68128 Mannheim, Germany

hitachienergy.com/rtu

We reserve the right to make technical changes or modify the contents of this document without prior notice. With regard to purchase orders, the agreed particulars shall prevail. Hitachi Energy does not accept any responsibility whatsoever for potential errors or possible lack of information in this document.

We reserve all rights in this document and in the subject matter and illustrations contained therein. Any reproduction, disclosure to third parties or utilization of its contents – in whole or in parts – is forbidden without prior written consent of Hitachi Energy.
© 2022 Hitachi Energy
All rights reserved

ABB is a registered trademark of ABB Asea Brown Boveri Ltd. Manufactured by/ for a Hitachi Energy company.