

Communication Unit 560CMR02

RTU560 product line



Communication module of the RTU560 with 32 bit CPU

- 6x serial communication interface (RS-232 or RS-485) for remote communication
- 2x Ethernet interface (10/100BaseT)
- 1x USB port
- 1x serial peripheral bus
- battery buffered real time clock

Application

The 560CMR02 communication unit is one of the CMU modules of the RTU560 product line.

The essential tasks are:

- Managing and controlling of the I/O modules via the interface to the serial I/O bus.
- Reading Process events from the input modules.
- Send commands to the output modules.
- Communicating with control systems and local HMI systems via the serial interface (RS232) and the Ethernet 10/100BaseT interfaces.
- Communication with Sub-RTU's, IED's or multimeter devices via the interfaces (RS485) and the Ethernet interfaces.
- Managing the time base for the RTU560 product line station and synchronizing the I/O modules.
- Handling the dialog between RTU560 product line and Web-Browser via the LAN interfaces.

Within the RTU560 racks the board occupies two slots. The communication unit is able to handle Ethernet- and UART-character based communication protocols.

The unit has a battery buffered real time clock (RTC).

The unit is available in 2 versions:

- R0001: with standard cyber security functions
- R0002: with security chip for advanced cyber security functions

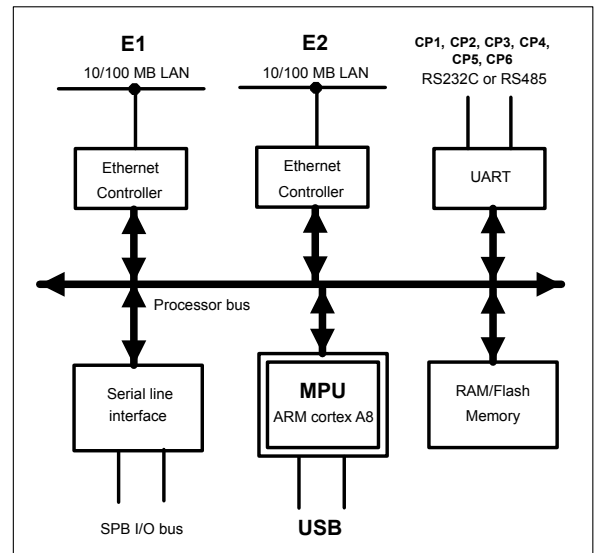

Figure 1: Block diagram 560CMR02

Characteristics

On the applied ARM cortex A8 controller AM3352 a real-time operating system is implemented. The 560CMR02 is responsible for the interface management, the event handling, the time base and the internal data base. The controller acts as master for the SPB I/O bus (serial

peripheral bus). RTU560 synchronizes itself to the time references supplied by 560RTC0x. The time information of the 560RTC0x is provided to the 560CMR02 on the backplane of the sub-rack.

System relevant configuration files are stored in the non-volatile flash memory card (removable SD-card™) in order to guarantee a valid system configuration after Power on Reset (PoR).

A battery buffered RTC is used to keep an exact time during power off state.

The communication unit provides the following interfaces:

- Communication Port 1 ... 6 (CP1 ... CP6): serial interfaces according RS232C or RS485 with RJ45 connectors. CP1 and CP2 can be configured independant as SPB I/O bus interface to the front.
- Ethernet interface 1 and 2 (E1 & E2): 10/100BaseT with RJ45 connector.
- USB 2.0 device interface for diagnosis and maintenance purposes.
- The SPB I/O bus is directly connected to the backplane connector.

Technical data

In addition to the RTU500 series general technical data, the following applies:

Main Processing Unit MPU	
CPU	ARM cortex A8, AM3352 @ 800 MHz
RAM	128 MByte
Boot Flash	8 MByte

SD card	
Connector	SD card slot (push push)
Type	SD 2.0, class 2
Capacity	4 GByte

Real time clock RTC (Backup)	
Battery	Lithium 3 V DC, CR2032
Time resolution	1 sec, 1ms with timesync
Battery lifetime	> 10 years
Free running	± 50 ppm

Serial interfaces 1, 2, 3, 4, 5 and 6		
Connector	RJ45	
Type	RS232C or RS485	
RS232C:		
Bit rate	200 bit/s - 38.4 kbit/s	
Signal lines	GND	E2/102
	TxD	D1/103
	RxD	D2/104
	RTS	S2/105
	CTS	M2/106
	DTR	S1.2/108
	DCD	M5/109
Level	typical: ± 6V	
RS485:		
Bit rate	200 bit/s - 38.4 kbit/s	
Level	typical: ± 6V	

Ethernet interface E1 and E2	
Connector	RJ45
Type	IEEE 802.3, 10/100BaseT

USB interface	
Connector	micro USB Type AB (female)
Type	USB 2.0 device, low, full and high speed (max. 480 MBit/s)
Cable type to PC	USB Type A <-> micro USB Type B

Current consumption for power supplied via RTU560 backplane

5 V DC	600 mA
24 V DC	4 mA

Signaling by LEDs

ERR (red)	ON: RTU in error state Flashing: RTU in warning state For more details see RTU500 series Function Description
RUN (green)	Communication module in operation
T	Transmit data on serial communication ports CP
R	Receive data on serial communication ports CP
S	Ethernet communication speed: ON: 100 Mbit/s OFF: 10 Mbit/s
L	Link up (ON) / Activity (Flashing) on Ethernet interface E

Mechanical layout

Dimensions	160 mm x 100 mm, 3HE euro card format 8R (40 mm) front panel
Housing type	Printed circuit board
Mounting	for mounting in RTU560 racks
Weight	0.19 kg

Connection type

RTU560 backplane connector	48 pole type F DIN 41612
----------------------------	--------------------------

Immunity test

Electrostatic discharge IEC 61000-4-2	8 kV air / 6 kV contact (level 3) Performance criteria A
Radiated Radio-Frequency Electromagnetic Field IEC 61000-4-3	10 V/m (level 3) Performance criteria A
Electrical Fast Transient / Burst IEC 61000-4-4	4 kV (level X) Performance criteria A
Surge IEC 61000-4-5	2 kV (level 3) Performance criteria A
Conducted Disturbances, induced by Radio-Frequency Fields IEC 61000-4-6	10 V (level 3) Performance criteria A

Immunity test

Damped oscillatory wave IEC 61000-4-18	2.5 / 1 kV (level 3) Performance criteria A
---	--

Environmental conditions - climatic

Operating temperature EN 60068-2-14	-25 °C ... 70 °C
--	------------------

Start up EN 60068-2-1	-40 °C
--------------------------	--------

Max. operating temperature, +85 °C max. 96h EN 60068-2-2	
--	--

Relative humidity EN 60068-2-30	5 ... 95 % (non condensing)
------------------------------------	--------------------------------

Ordering information

560CMR02 R0001	1KGT036300R0001
----------------	-----------------

560CMR02 R0002	1KGT036300R0002
----------------	-----------------
