

Power supply 560PSR00 RTU560 product line



Power supply unit for RTU560 racks

- Input voltage 24...60 V DC
- Output voltage: 5 and 24 V DC
- Suitable for redundant power supply in 560MPR03/560SFR02

Application

The power supply unit 560PSR00 generates the two supply voltages (5 V DC and 24 V DC) for the RTU560 subracks 560MPR03 and 560SFR02. The output power is sufficient to supply a subrack with up to 8 communication units (560CMR01/02).

It is possible to configure redundant power supplies for project configurations with higher requirements to availability. In this configuration two power supply units 560PSR00 are operating in parallel mode. They are able to take over the full load, if one power supply fails. Only power supplies of the same type and rubric should be used for redundant operation.

The power supply unit 560PSR00 is available in the following version (rubric):

- R0001 Input range 24 ... 60 V DC (-20%... +15%)

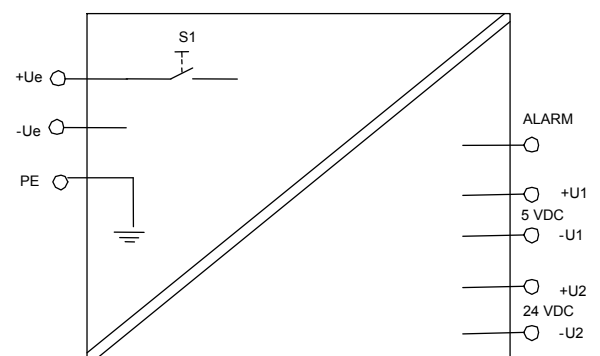

Figure 1: Block diagram 560PSR00

Characteristics

The power supply unit 560PSR00 has the following characteristics and functions:

- Potential isolation between the input and the outputs
- Cooling by natural convection
- Electronic power limitation on outputs
- Short-circuit proof outputs
- Over-voltage protection of the input
- Reverse voltage protection of the input
- Parallel operation with monitoring of redundant power supply configuration
- Controlled load balancing in redundant operation
- LEDs for monitoring the output voltages

- Alarm indication in case of failure
- Tolerant on input voltage interruptions up to 50 ms

Technical data

In addition to the RTU500 series general technical data, the following applies:

Power supply input	
Input voltage	24 ... 60 V DC
Input tolerance range	-20%... +15%
Voltage Interruption	≤ 50ms; 0% Un; >48 V DC
Max. input current	2.3 ... 0.9 A
Starting current	<10 A; 50µs - 1.5ms (Class S1 according to IEC 60870-4)
Efficiency	85%
External circuit-breaker	The plus lead has to be protected by an upstream circuit-breaker with 10 A tripping current.
Reverse voltage protection	yes
Potential isolation between input and outputs	yes

Power supply output	
Total output power	44.3 W
Derating	-2,5 % / Kelvin; ≥ 55 °C

Output U1	
Voltage	5.1 V DC
Tolerance	5.0... 5.3 V DC
Current min.	0.2 A
Current max.	5.5 A
Residual Ripple	≤ 30 mV _{SS}

Output U2	
Voltage	24 V DC
Tolerance	22.4... 26.3 V DC
Current min.	0 A
Current max.	0.7 A
Residual Ripple	≤ 80 mV _{SS}

Mechanical layout	
Dimensions	160 mm x 100 mm, 3HE euro card format 8R (40 mm) front panel
Housing type	Printed circuit board
Mounting	for mounting in RTU560 racks
Weight	ca. 0,6 kg

Connection type	
RTU560 backplane connector	48 pole type F DIN 41612

Connection type	
Supply connector	3 pole 7.62 mm pluggable screw terminal PKB 960/3/7,62 GN (included in delivery) 0.2... 2.5 mm ² / AWG 24 - AWG 12

Immunity test	
Electrostatic discharge IEC 61000-4-2	8 kV air / 6 kV contact (level 3) Performance criteria A
Electrical fast transient / Burst IEC 61000-4-4	2 kV (level 3) Performance criteria A
Surge IEC 61000-4-5	2 kV (level 3) Performance criteria A
Damped oscillatory wave IEC 61000-4-18	2.5 / 1 kV (level 3) Performance criteria A

Environmental conditions - climatic	
Operating temperature EN 60068-2-14	-25 °C ... 70 °C
Start up EN 60068-2-1	-40 °C
Relative humidity EN 60068-2-30	5 ... 95 % (non condensing)

Ordering information	
560PSR00 R0001	1KGT026500R0001

ABB Power Grids Germany AG

P.O. Box 10 03 51
68128 Mannheim, Germany

hitachiabb-powergrids.com/rtu

We reserve the right to make technical changes or modify the contents of this document without prior notice. With regard to purchase orders, the agreed particulars shall prevail. Hitachi ABB Power Grids does not accept any responsibility whatsoever for potential errors or possible lack of information in this document.

We reserve all rights in this document and in the subject matter and illustrations contained therein. Any reproduction, disclosure to third parties or utilization of its contents – in whole or in parts – is forbidden without prior written consent of Hitachi ABB Power Grids.
© 2021 Hitachi Power Grids
All rights reserved

ABB is a registered trademark of ABB Asea Brown Boveri Ltd. Manufactured by/ for a Hitachi Power Grids company.